

 Applies To: **See VEHICLES AFFECTED**
December 14, 2005

Headlights Dim or DTC P1298 Is Stored in the ECM/PCM

(Supersedes 05-034, dated September 13, 2005, to update the information marked with the black bars)

SYMPTOM

The headlights dim with the engine running and the headlights on, or DTC P1298 [electronic load detector (ELD) circuit high voltage] is stored in the ECM/PCM (but the headlights do not dim).

PROBABLE CAUSE

The ELD has a faulty solder joint.

VEHICLES AFFECTED

2003-04 Accord – ALL

2005 Accord (L4 2-door):

From VIN 1HGCM7...5A000001 thru
1HGCM7...5A006329

2005 Accord (L4 4-door):

From VIN 1HGCM5...5A000001 thru
1HGCM5...5A035840

From VIN 3HGCM5...5G700001 thru
3HGCM5...5G701907

All Japan-built (VIN begins with JHM)

2005 Accord (V6 2-door):

From VIN 1HGCM8...5A000001 thru
1HGCM8...5A005073

2005 Accord (V6 4-door):

From VIN 1HGCM6...5A000001 thru
1HGCM6...5A017546

2003 Element – ALL

2004 Element (2WD):

From VIN 5J6YH1...4L000001 thru
5J6YH1...4L015490

2004 Element (4WD):

From VIN 5J6YH2...4L000001 thru
5J6YH2...4L037697

2005 Odyssey:

From VIN 5FNRL38..5B000001 thru
5FNRL38..5B018359

CORRECTIVE ACTION

Accord and Odyssey: Replace the under-hood fuse/relay box.

Element: Replace the ELD.

PARTS INFORMATION

Electronic Load Detector:

P/N 38255-S5A-003, H/C 7987571

Under-hood Fuse/Relay Box:

2003-04 Accord L4 – 2-door LX/EX, 4-door EX
P/N 38250-SDA-A21, H/C 7136617

2003-04 Accord L4 – 4-door DX
P/N 38250-SDA-A11, H/C 7136609

2003-04 Accord L4 – 4-door LX
P/N 38250-SDA-A01, H/C 7136591

2003-04 Accord V6 – All
P/N 38250-SDB-A21, H/C 7136641

2005 Accord L4 – DX
P/N 38250-SDA-A12, H/C 7773799

2005 Accord L4 – LX
P/N 38250-SDA-A02, H/C 7773781

2005 Accord L4 – EX
P/N 38250-SDA-A22, H/C 7773807

2005 Accord V6 – All
P/N 38250-SDB-A22, H/C 7773831

2005 Odyssey – LX
P/N 38250-SHJ-A01, H/C 7708191

2005 Odyssey – EX, EX-L, Touring
P/N 38250-SHJ-A21, H/C 7708209

WARRANTY CLAIM INFORMATION

In warranty: The normal warranty applies.

OP#	Description	FRT
7301A1	<i>Accord and Odyssey</i> - replace the under-hood fuse/relay box	0.5
121195	<i>Element</i> - replace the ELD	0.4

Failed Part: P/N 38255-S5A-003
H/C 7987571

Defect Code: 03217

Symptom Code: 07411

Skill Level: Repair Technician

Out of warranty: Any repair performed after warranty expiration may be eligible for goodwill consideration by the District Parts and Service Manager or your Zone Office. You must request consideration, and get a decision, before starting work.

DIAGNOSIS

If the headlights dim when the engine is running, connect the HDS to the DLC:

1. With the HDS in the **PGM-FI Data List**, start the engine, and let it idle.
2. Turn on the headlights.
3. Monitor the ELD value on the **Data List**.
 - If the ELD value is less than 18 amps:
 - For *Accord*, go to **REPAIR PROCEDURE A – ACCORD**
 - For *Odyssey*, go to **REPAIR PROCEDURE B – ODYSSEY**
 - For *Element*, go to **REPAIR PROCEDURE C – ELEMENT**
 - If the ELD value is greater than 18 amps, disregard this bulletin, and continue with normal troubleshooting.

NOTE: A faulty ELD may cause the charging system to fluctuate between 12.5-volt and 14.5-volt modes with the engine running and the headlights on. This fluctuation causes the headlights to dim. Under normal operating conditions, the charging system operates in the 14.5-volt mode.

If the headlights do not dim, but DTC P1298 is stored in the ECM/PCM:

- For *Accord*, go to **REPAIR PROCEDURE A – ACCORD**
- For *Odyssey*, go to **REPAIR PROCEDURE B – ODYSSEY**
- For *Element*, go to **REPAIR PROCEDURE C – ELEMENT**

NOTE: When DTC P1298 is set, the charging system is fixed in the 14.5-volt mode, preventing the headlights from dimming.

REPAIR PROCEDURE A – ACCORD

1. Replace the under-hood fuse/relay box:
 - Refer to page 22-71 of the 2003–05 Accord Service Manual, or
 - Online, enter keyword **UNDER-HOOD REM**, and select **Under-hood Fuse/Relay Box Removal and Installation** from the list.
2. If necessary, clear the DTC with the HDS.

REPAIR PROCEDURE B – ODYSSEY

1. Replace the under-hood fuse/relay box:
 - Refer to page 22-85 of the 2005–06 Odyssey Service Manual, or
 - Online, enter keyword **UNDER-HOOD REM**, and select **Under-hood Fuse/Relay Box Removal and Installation** from the list.
2. If necessary, clear the DTC with the HDS.

REPAIR PROCEDURE C – ELEMENT

1. Make sure you have the anti-theft code for the audio system. Write down the customer's audio unit presets.
2. Disconnect the negative battery cable from the battery.
3. Remove the under-hood fuse/relay box cover.
4. Release the three clips, and remove the under-hood fuse/relay box from the holder. Release the wire harness clip from the fuse/relay box holder.

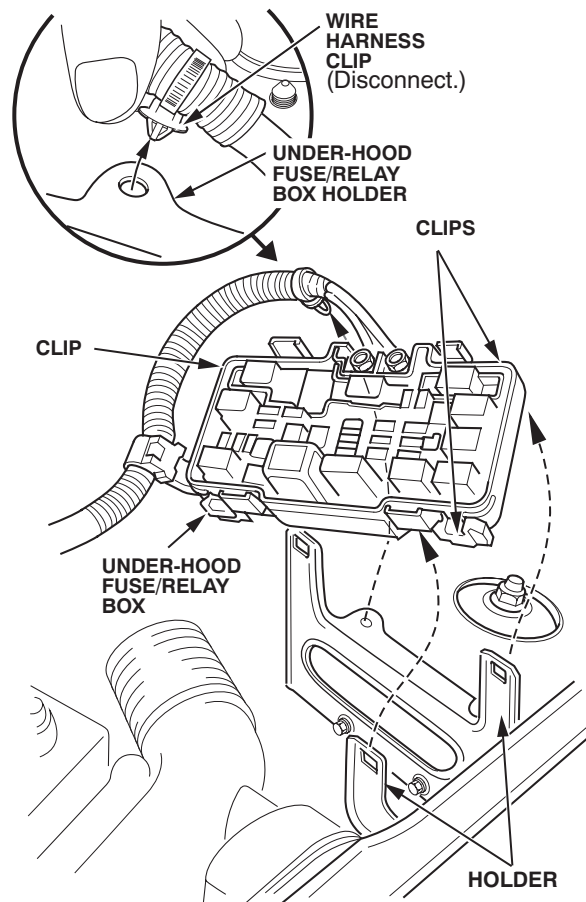

5. Remove the lower cover from the fuse/relay box.

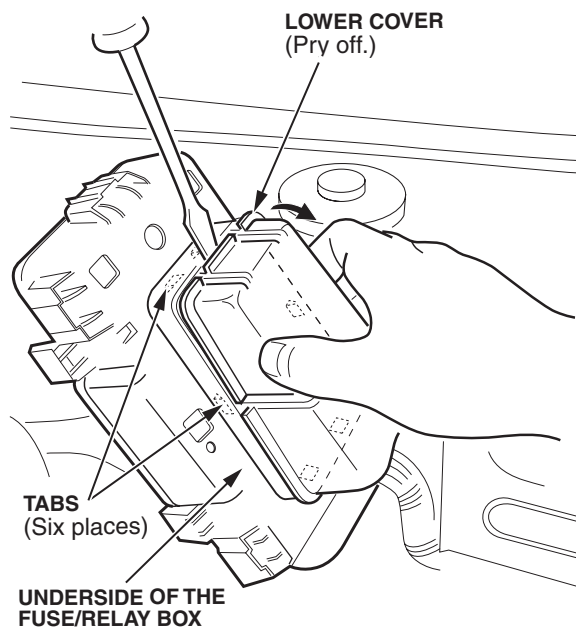

6. Disconnect the 3P ELD connector.

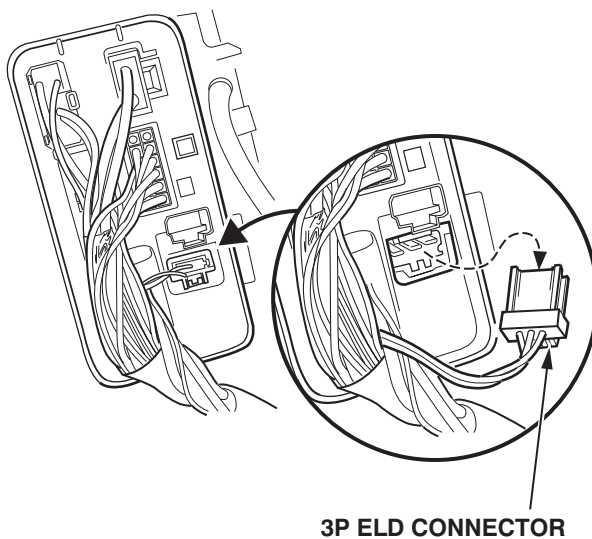

7. Remove the four screws that hold the two fuses, then remove the fuses.

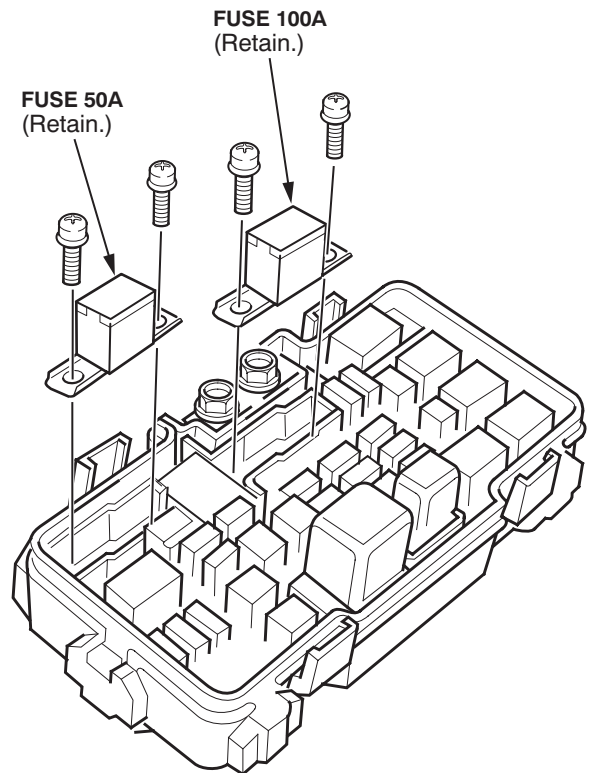

8. Release the tab that holds the ELD, and pull up on the ELD to remove it.

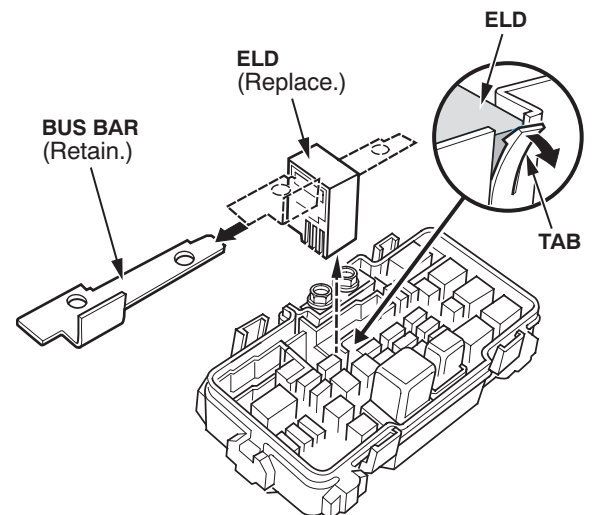

9. Remove the bus bar from the ELD, and insert the bar into the new ELD.
10. Install the new ELD and bus bar.
11. Reinstall the two fuses.
12. Reconnect the 3P ELD connector, and reinstall the lower cover onto the fuse/relay box.
13. Reinstall the fuse/relay box and the wire harness clip onto the holder.

14. Reinstall the fuse/relay box cover.
15. Reconnect the negative battery cable.
16. Clear the DTC.
17. Reset the power window control unit:
 - Turn the ignition switch to ON (II), and make sure the driver's window AUTO function does not work.
 - Start the engine.
 - Push down the driver's power window switch to the second detent (AUTO down) to lower the driver's window all the way down. When the window reaches the bottom, hold the switch in the AUTO down position for **2 more seconds**.
 - Pull up the driver's power window switch to raise the driver's window all the way up without stopping. When the window reaches the top, hold the switch in the up position for **2 more seconds**.
 - If the driver's window AUTO function does not work, repeat this power window control unit reset procedure.
18. Do the idle learn procedure:
 - Make sure all electrical items (A/C, audio unit, defogger, lights, etc.) are off.
 - Start the engine, and let it warm up to its normal operating temperature (the cooling fans cycle twice).
 - Let the engine idle (throttle closed and all electrical items off) for **10 minutes**.
19. Enter the audio system anti-theft code, and set the clock. Enter the audio unit presets.